

This catalogue shows our range of surface mounting, small size jacks. For quantities under 1000pcs, most items can be supplied as loose components. For quantities over 1k, components can be supplied taped 1000pcs / reel. Add suffix 'T' to part number for taped version.

All SMD parts can be reflow soldered for 2 to 5 secs @ 260°C. Since all jacks have contact surfaces, precautions against ingress of flux should be taken.

All parts are RoHS compliant and are not sensitive to static.

DC POWER JACK

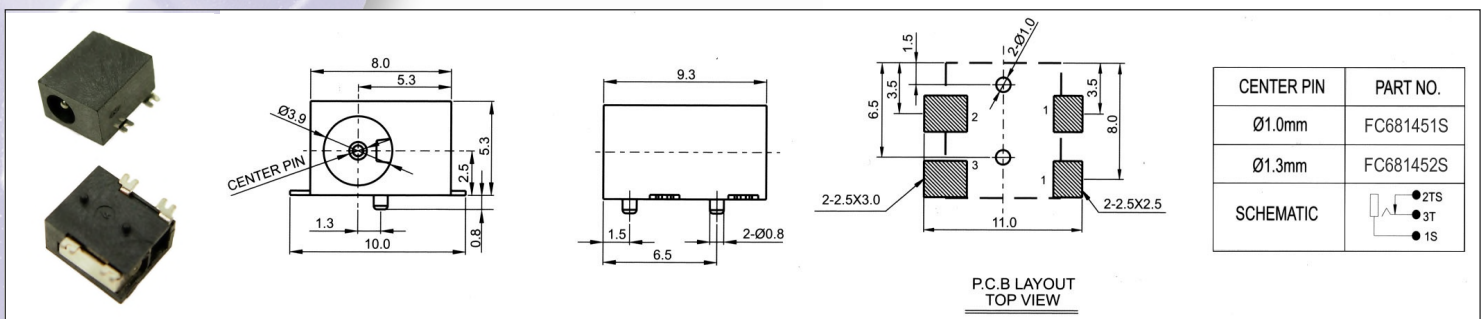

Technical drawing showing dimensions and PCB layout for a DC Power Jack. The drawing includes a top view of the component with dimensions: 8.0mm width, 5.3mm height, 1.3mm offset, 10.0mm total width, 0.8mm offset, 2.5mm height, and 5.3mm total height. A center pin is indicated with a diameter of $\varnothing 3.9$. A side view shows a total width of 9.3mm and a mounting hole diameter of $2-\varnothing 0.8$. A detailed PCB layout top view shows a 11.0mm width, 6.5mm height, and 1.5mm offset. It features two 2.5x3.0mm pads and two 2.5x2.5mm pads. A center pin diameter of $\varnothing 1.0$ is shown. A schematic diagram shows a 3-pin configuration: 2TS, 3T, and 1S.

CENTER PIN	PART NO.
$\varnothing 1.0$ mm	FC681451S
$\varnothing 1.3$ mm	FC681452S
SCHEMATIC	

P.C.B LAYOUT TOP VIEW

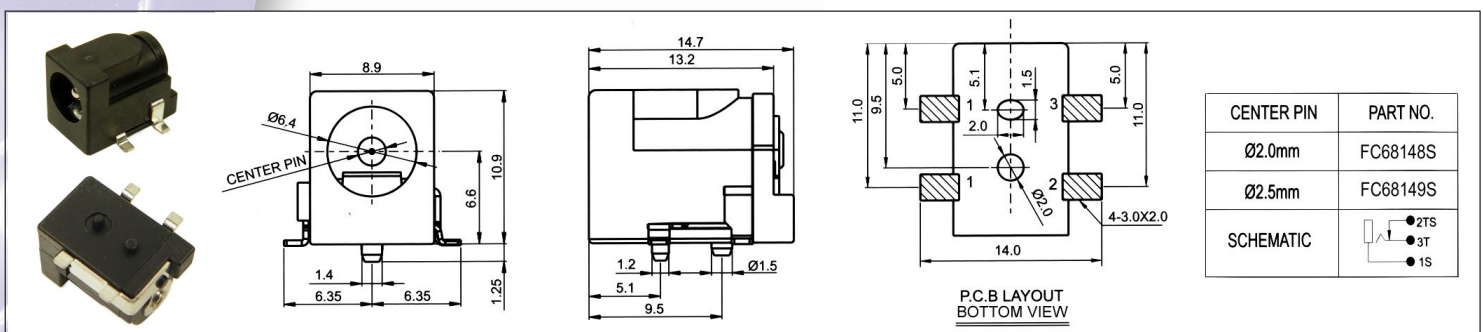

Technical drawing showing dimensions and PCB layout for a DC Power Jack. The drawing includes a top view of the component with dimensions: 8.9mm width, 10.9mm height, 6.6mm offset, 1.4mm offset, 6.35mm offset, and 1.25mm offset. A center pin is indicated with a diameter of $\varnothing 6.4$. A side view shows a total width of 14.7mm, a mounting hole diameter of $\varnothing 1.5$, and a 1.2mm offset. A detailed PCB layout bottom view shows a 14.0mm width, 11.0mm height, and 9.5mm offset. It features two 4-3.0x2.0mm pads and two 2.0mm pads. A center pin diameter of $\varnothing 2.0$ is shown. A schematic diagram shows a 3-pin configuration: 2TS, 3T, and 1S.

CENTER PIN	PART NO.
$\varnothing 2.0$ mm	FC68148S
$\varnothing 2.5$ mm	FC68149S
SCHEMATIC	

P.C.B LAYOUT BOTTOM VIEW

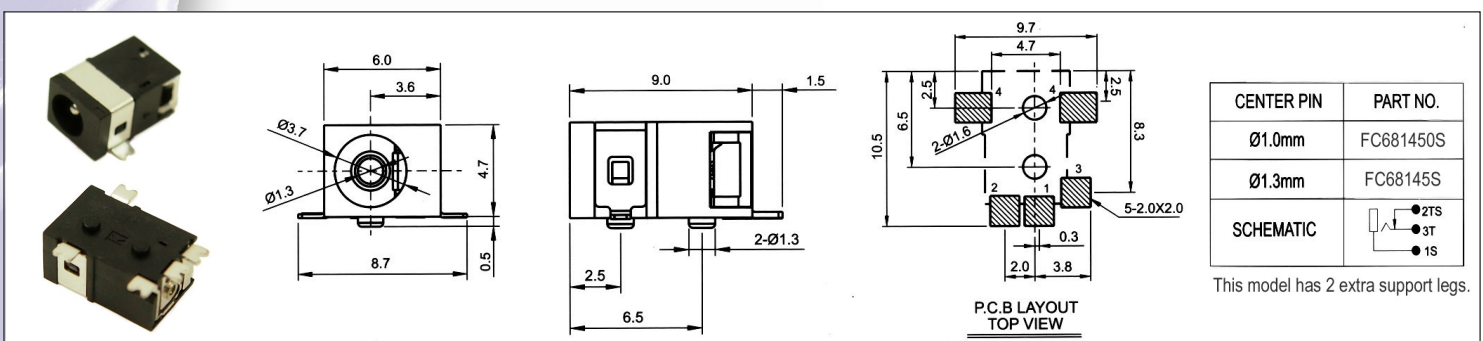

Technical drawing showing dimensions and PCB layout for a DC Power Jack. The drawing includes a top view of the component with dimensions: 6.0mm width, 4.7mm height, 3.6mm offset, 0.5mm offset, 8.7mm total width, and 0.5mm offset. A center pin is indicated with a diameter of $\varnothing 3.7$. A side view shows a total width of 9.0mm, a mounting hole diameter of $2-\varnothing 1.3$, and a 2.5mm offset. A detailed PCB layout top view shows a 9.7mm width, 10.5mm height, and 6.5mm offset. It features two 2- $\varnothing 1.6$ pads and two 5-2.0x2.0 pads. A center pin diameter of $\varnothing 1.3$ is shown. A schematic diagram shows a 3-pin configuration: 2TS, 3T, and 1S.

CENTER PIN	PART NO.
$\varnothing 1.0$ mm	FC681450S
$\varnothing 1.3$ mm	FC68145S
SCHEMATIC	

This model has 2 extra support legs.

P.C.B LAYOUT TOP VIEW

Cliff Electronic Components, Ltd.

76 Holmethorpe Avenue, Holmethorpe Ind. Est.
Redhill, Surrey RH1 2PF. England

Tel: +44 (0) 1737 771375

Fax: +44 (0) 1737 766012

Email: sales@cliffuk.co.uk



Visit us online at:

www.cliffuk.co.uk

2.5mm JACK SOCKET

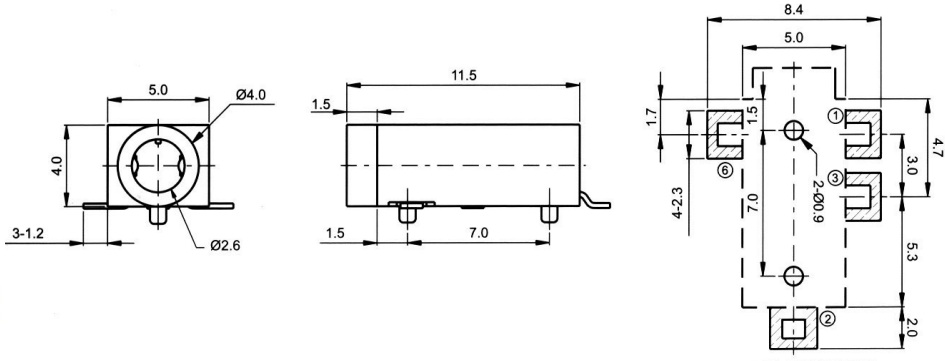

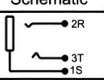
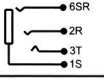

**RECOMMENDED
SOLDER PAD LAYOUT**

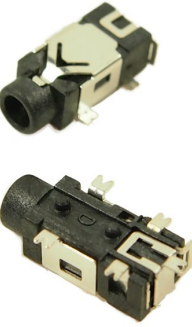
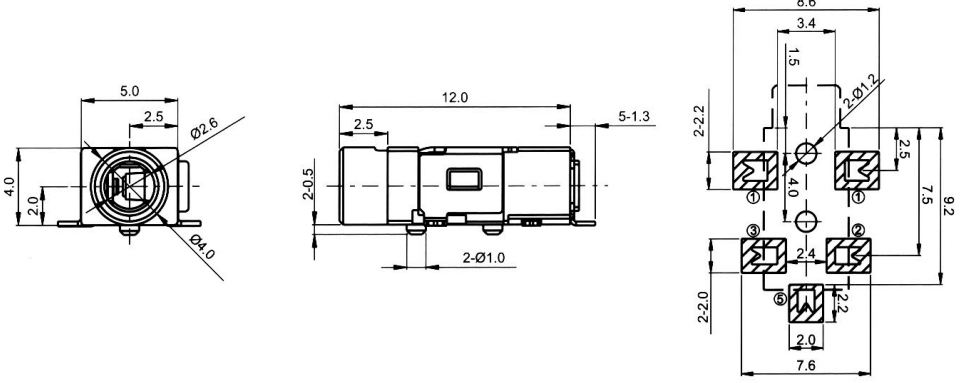
Model No.	Schematic
FC68104SA	
FC68104SB	



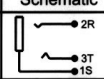
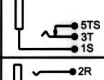
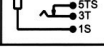

**RECOMMENDED
SOLDER PAD LAYOUT**

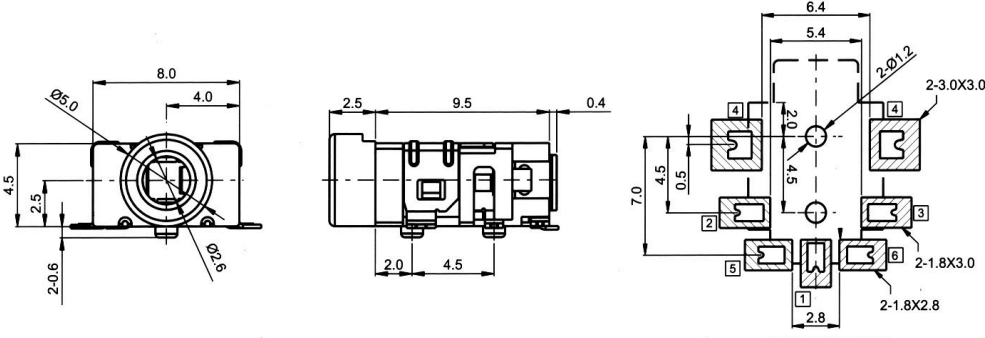
Model No.	Schematic
FC68104SC	
FC68104SD	
FC68104SE	



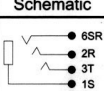
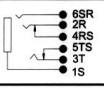

**RECOMMENDED
SOLDER PAD LAYOUT**

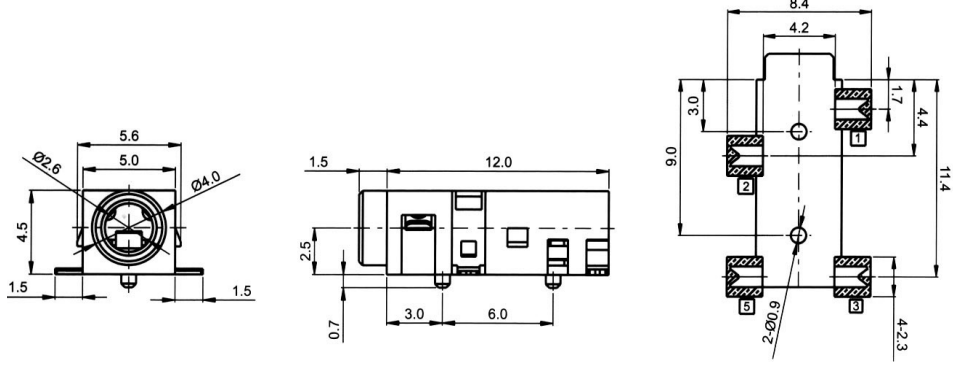
Model No.	Schematic
FC68104SF	
FC68104SG	



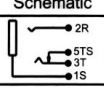

**RECOMMENDED
SOLDER PAD LAYOUT**

Model No.	Schematic
FC68104SH	

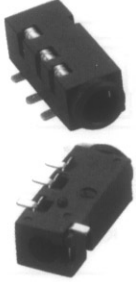
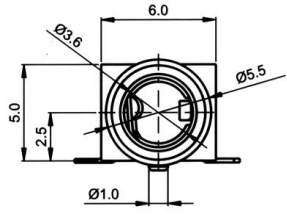
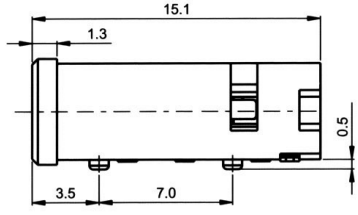
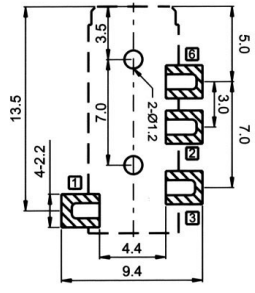

3.5mm JACK SOCKET

Model No.	Schematic
FC68123SA	
FC68123SB	



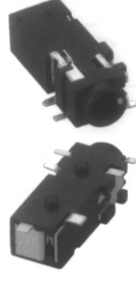
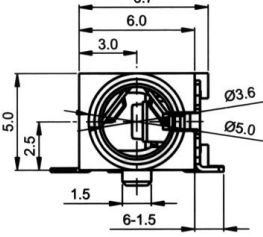
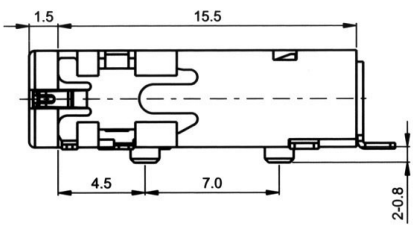
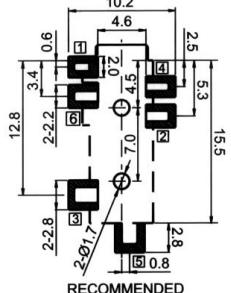

RECOMMENDED SOLDER PAD LAYOUT

Model No.	Schematic
FC68123SC	
FC68123SD	

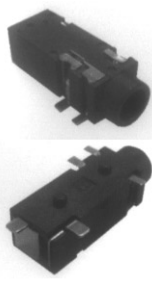
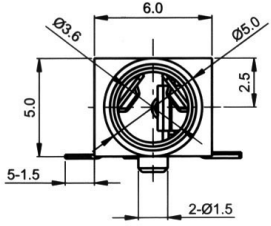
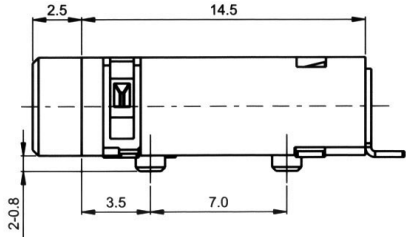
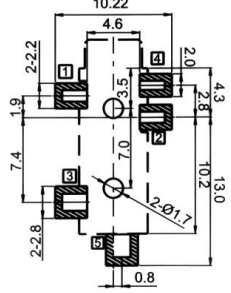
RECOMMENDED SOLDER PAD LAYOUT

Model No.	Schematic
FC68123SE	
FC68123SF	
FC68123SG	
FC68123SH	
FC68123SJ	

RECOMMENDED SOLDER PAD LAYOUT

Model No.	Schematic
FC68123SK	

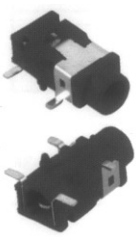
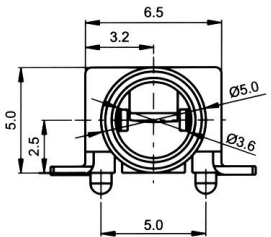
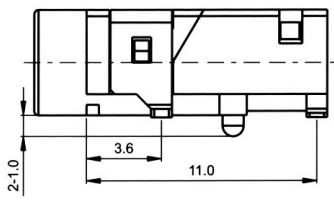
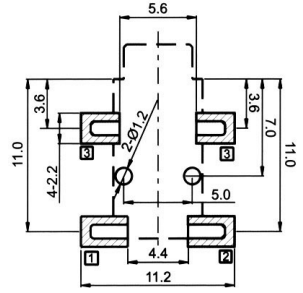
RECOMMENDED SOLDER PAD LAYOUT

Model No.	Schematic
FC68123SL	

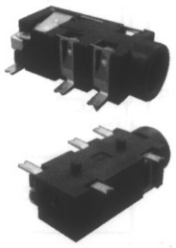
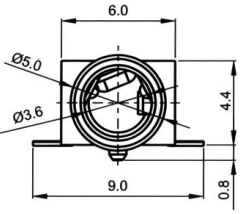
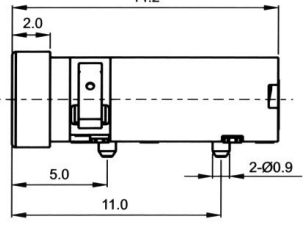
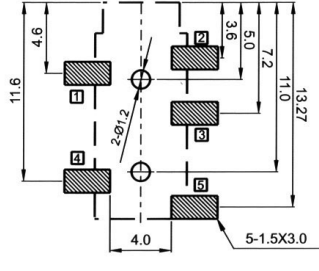
RECOMMENDED SOLDER PAD LAYOUT